A nighttime photograph of a city canal, likely in Gothenburg, Sweden. The water is dark and reflects the lights from the buildings and street lamps. On the right, a prominent church tower with a clock face is visible. The sky is a deep blue, and the overall scene is illuminated by warm yellow and white lights from the buildings and street lamps.

Everyday Key Word Signing (KWS): Overcoming challenges to real communication

Nicola Grove PhD
Rix Inclusive Research
University of East London

Berätta mer – Tell me more.
Communications Carnival
Gothenburg
11-12 November 2025

MANUAL SIGN ACQUISITION IN CHILDREN WITH DEVELOPMENTAL DISABILITIES

EDITORS: Nicola Grove, PhD (Tizard Centre, University of Kent, United Kingdom, UK) and Kaisa Launonen, PhD (Department of Psychology & Logopaedics, Faculty of Medicine, University of Helsinki, Finland) **SERIES:** Languages and Linguistics

HARDCOVER ISBN: 978-1-53615-377-4 **eBOOK ISBN:** 978-1-53615-378-1
RETAIL PRICE: \$250 **SPECIAL PRICE:** \$150

BOOK DESCRIPTION: Manual signs are used worldwide to support the communication and language development of children who have developmental disabilities. This book provides an overview of forty years of research and practice by recognised experts, from a developmental perspective. Uniquely, the book includes contributions on both sign languages and sign systems, linking the two fields of Deaf studies and Augmentative and Alternative Communication which have historically been seen as separate. This text is the most authoritative single text to date on the topic, providing an invaluable resource for speech pathologists, researchers, psychologists and educators.

The main sections of the book include: the typical development of sign language and of gesture; literature reviews on sign acquisition in children with disabilities such as Down syndrome, autism spectrum disorders, Llandau Kleffner syndrome and deaf blindness. An important chapter deals with the latest research on sign language impairments in deaf children with developmental language difficulties, or autism spectrum disorders. The third section of the book addresses assessment and intervention, covering vocabulary, sign production difficulties and intelligibility, grammar and multi-signing, and pragmatics and discourse skills.

The final two sections are concerned with use of signs in context: in the home, in school, and in different cultures. Throughout, care is taken to ensure that the voices of users are present and vivid, whether these be family members, teaching staff or the children themselves, with an entire chapter given over to an interview with a young adult's reflections on her use of sign since childhood. The book concludes with a call for a multimodal perspective on augmentative communication to be adopted in the future.

ORDER TODAY & SAVE

To place an order, please visit our website at www.novapublishers.com and be sure to enter promotion code **SIGNING** at checkout and **SAVE \$120***

***Limited time only so place your order today!**

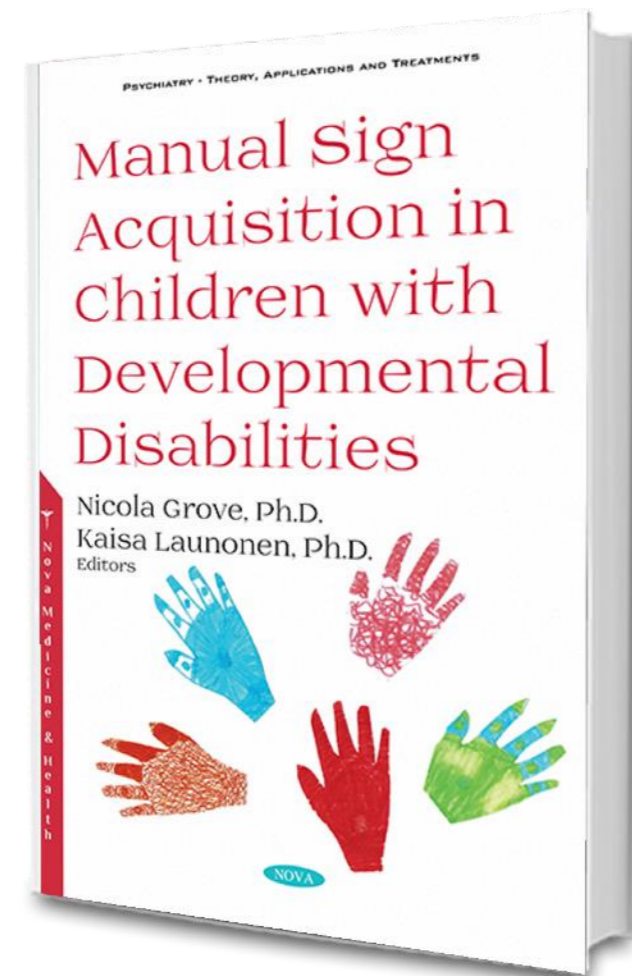

400 Oser Avenue, Suite 1600, Hauppauge, NY 11788-3619, USA
Phone (631) 231-7269 Fax (631) 231-8175
Email: nova.main@novapublishers.com www.novapublishers.com

What is Key Word Signing?

- “Umbrella” term for all manual systems of communication using spoken language and accompanying signs
- Sign supported communication.
- Choice of which words to sign lies with the speaker
- Usually content words – but function words such as deictics may be included as points
- “an intuitive, dynamic and complex form of simultaneous communication using signs adopted from the natural language of the Deaf community”
(Grove & Launonen 2019)

What is Key Word Signing?

Sign Language
Cultural language of the Deaf community.
No spoken words
Rules and grammar



Natural gestures - part of everyday communication for us all



Key Word Signing

Natural speech + signs for important "words"
Used with hearing children and adults with SENDs (some may also be deaf)

Draws on vocabulary of sign language



Problems with KWS

- Low awareness regarding communication and language development
- Problems with continuity in instruction and practicing.
- Users of sign are highly responsive to the communication environment – if others are not using sign, they won't – creating negative spiral
- Fragility -specifically during transition-
- Lack of information about the person
- Assumptions that people with motor impairments will not use or benefit
- Individuals with dyspraxia may be regarded as lazy/unmotivated
Sometimes signing is not supported by other systems (except of visual schedules) when persons with motor conditions have difficulties using them themselves -most often due to dyspraxia. Overall persons with dyspraxia are often misunderstood being seen as unwilling, lazy or provocative due their inconsistent use and quality of signing.
- Belief that tmanual signing is the AAC form that should mandatory be used with persons with DS.

Problems with establishing KWS: Families (Glacken et al, 2019; Smidt et al, 2025)

- Requires acceptance and recognition of need to change habitual communication style
- Sustained parental and family commitment needed: Cognitive effort involved – parents exhaustion
- May be a long lead in time before benefits to child are apparent
- Lack of training and support
- Reluctance to use outside home setting
- Need to bring whole family on board

Flink et al 2025;
Wallin, 2023,
2024: Sweden

- 11 teachers and 17 support staff from seven schools working in non-inclusive classrooms for students with ID in Sweden (Wallin et al., 2023), 82% of the teachers and 59% of the support staff had some kind of AAC education, most commonly focussing on manual signs. Out of the targeted AAC modes, manual signs were used most frequently (40% of all utterances during circle time, 9.8% during leisure time activities),

Wallin conclusions

- Consistent use of communication partner strategies by school staff is critical for enhancing student communication. Regular staff training and support may be necessary to address high turnover rates among support staff and to ensure these strategies are applied consistently over time. Improved access to personalized communication systems and better integration of AAC into daily activities are recommended to support students with ID effectively.

KWS in practice: Teachers in special schools

(Grove & McDougall, 1991;
Rombouts et. al, 2019)

- Teacher sign frequency in 10 schools (Grove & McDougall, 1991) 5 minutes \bar{x} 15.6 (0-66, SD 15.4)
- 10 hearing children with intellectual disabilities, spontaneous signers, filmed in conversation with teachers (5 minutes). 8 schools.
- No. of signs used in total \bar{x} 57.1 (15-160;sd 51.44)
- Signs per clause \bar{x} 1.45(1.00-2.52; sd 0.48), in 58% of clauses
- Only 2 teachers regularly produced multisign clauses
- 12 signing children filmed in 10 minute conversation with 4 teaching assistants (Mellon, 2001: 1 school) \bar{x} 125 (50-425)

KWS in practice:

- Staff signing varies across schools, contexts, and classes
- Highest in “teaching situations” (80%) lowest in informal contexts such as mealtimes playground, cooking, arts & crafts (20%).
- Teachers report varying levels of sign depending on perceived needs of the child (“he understands when I speak to him”); presence of children who “need sign”; organizational support

High and low sign environments
(Grove & McDougall, 1991: 12 schools)
Rombouts et al. 2017)

HSE Signs used consistently & frequently

Signing used infrequently outside specific teaching

* Low signing children

High signing children more likely in HSE ? Direction

* Inconsistent exposure over time

Factors associated
with HSE
(classrooms and
schools)

- Active support from SMT (use by head teacher)
- Provision of training, regularly and frequently, for all staff
- Prominent use and promotion of sign
- Over 40% of children reported to use sign
- All staff encouraged to sign

Factors associated
with LSE (schools
& classrooms)
(1991)

- No sign co-ordinator in school
- No active involvement from head teacher & SMT
- Lack of regular training
- Choice of whether to use sign is up to individual staff preference – attitude critical
- Fewer than 25% of pupils reported to be signing

Signing by children

- Highly influenced by staff signing – children are more likely to sign if they see sign used around them
- Sensitive to status of sign in the environment
- Their output does not necessarily match the input –KWS describes how staff sign, but is not a description of child sign
- Multisigning children ignore word order of the input
- Innovate - creative modifications to signing

Problems with
establishing KWS

Intervention for common issues

■ His signing isn't clear

- Know your sign phonology (*Meier, 2019; Grove et al. 2019*)
- Look for simpler alternatives within the relevant SL lexicon
- Work on motor skills (*Lee Dunn, 1982; Grove, 1990; Grove et. al., 2019*)

■ She knows 300 signs but.....

- Work on verbs
- Extend the potential of the existing signs (modifications and deixis)
- Introduce new vocabulary that serves a purpose (*Darke et. al., 2019*)

■ He only uses single words/signs

- Start with sign /word + point as in normal development
- Work on sign modifications (morphology)
- Don't worry initially about word order anomalies - focus on the meaning and the purpose

No barrier to signing
Address sign dyspraxia –
using knowledge of sign
language (Dunn, 1982;
Dennis et al, 1982; Deherby,
1982; Grove, Dark &
Brownlie, 2019)
Sign within the individual's
space of attention
Consider affordances of
long holds and repetitions
(Grove, 2019)

Motor difficulties

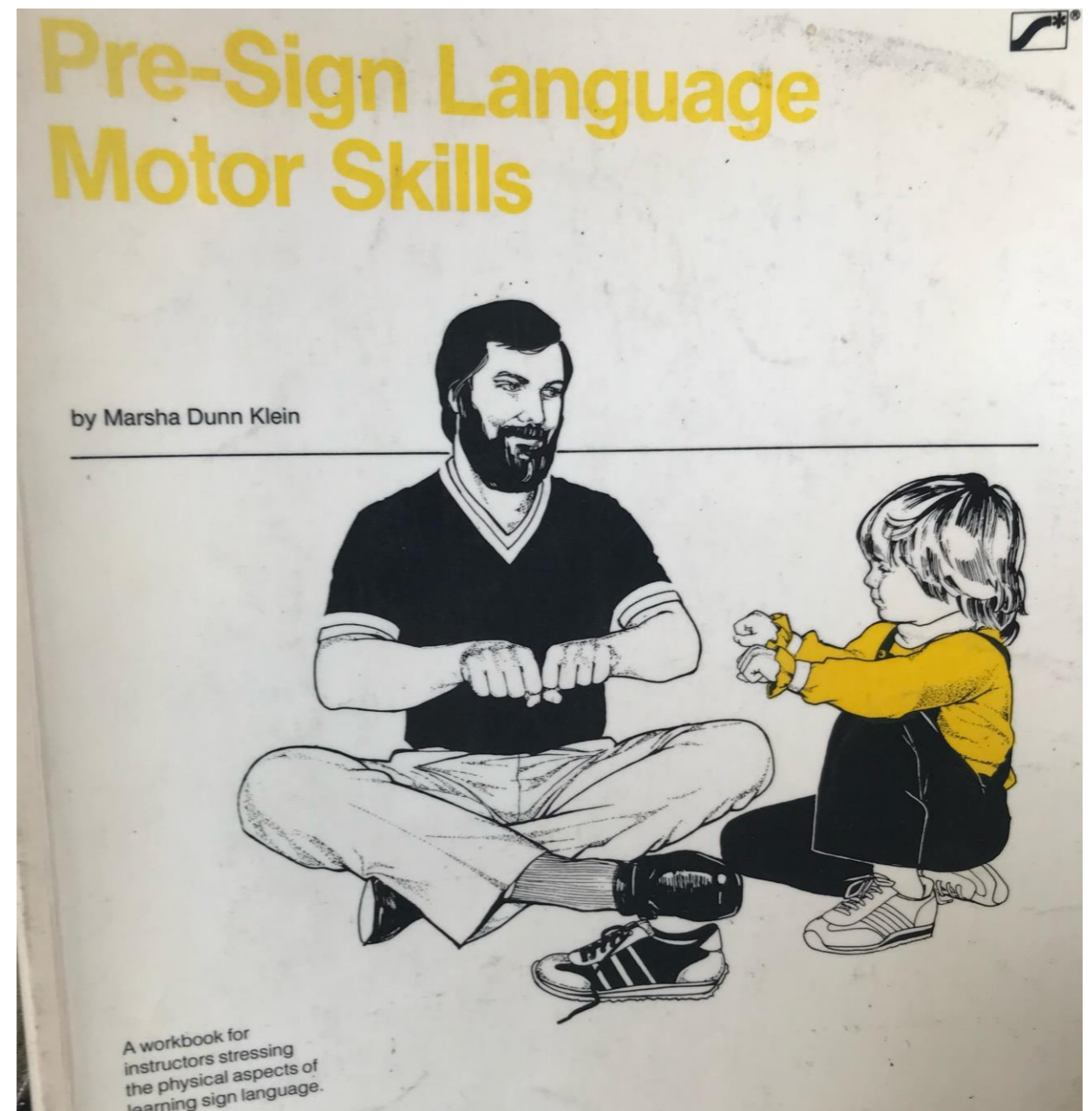

Tekin-Iftar, E. (2003).

Effectiveness of peer delivered simultaneous prompting on teaching community signs to students with developmental disabilities.

Education and Training in Developmental Disabilities, 77-94.

Peer tutoring

Hooper, H., & Bowler, D. M. (1991).

Peer-tutoring of manual signs by adults with mental handicaps.

Mental Handicap Research, 4(2), 207-215.

Drivers of Change

Clinical populations

- Deaf signing children with additional disabilities: ASD, children with CP needing aided systems
- Deaf children who do not benefit from cochlear implants because of additional disabilities: continuing need for sign
- Specific language impairments in sign: 7% of deaf children
- Deaf signing parents may have children with intellectual disabilities who sign
- *Herman et. al., 2014; 2019; Woll & Grove, 1996; 2019*

Person Centred approaches

- Rise of holistic co-productive approaches to developing communication intervention
- Self advocacy, identity and actualisation
- Continuing evidence that children (including ASD) may show distinct preferences for sign; may reject aided forms

Multimodality

- **New semiotic paradigms for communication**
 - Individuals mobilise a range of resources to meet communicative demands in the moment: dynamic, creative, co-operative and flexible *et. al. 2017*
- **Children's modality dependence (sign/speech/aided) is contextually variable over time and place rather than fixed (*Grove & McDougall, 1991*)**
- **Critical role of communication environment and communication partners: co-production. (*Rombouts et al, 2017; 2019; Mellon-Buchanan, 2001*)**

Children don't play by your rules...

- KWS is an inadequate descriptor for children's expressive use of sign. Children innovate! (*Grove, 1995; 2019*)
- Active use of gesture to achieve participation in discourse (*Grove, 2019; Parkhouse & Smith, 2019*)
- Clear contextual variation in the use of different modalities: changes with environment, communication partners, pragmatic functions and over time

How do
children
actually USE
sign

KW signers in special schools

- Wide range of modality dependence (intelligible signs: intelligible words) , varying with context
 - 16 “signers”; 11 “speakers”; 19 “in between” (*Grove & McDougall, 1991*)
 - Positive association between signing by teachers, classroom sign environments and signing by children (*Grove & McDougall, 1991; Buchanan Mellon 2001*)
- † Sign introduction is a cultural initiative (*Rombouts et. al. 2017; 2019*)

- Children who spontaneously changed the form of their signs to communicate particular meanings
- Children who failed to reproduce the word order of the spoken input in their signed output

Observations
1986-1990

1995 Main Findings: syntax

- **Word order did not always match that of the input**
 - Agents preceded Actions; Patients preceded or followed Actions
 - Same patterns observed in speech and in sign - deviation from the input model {CAKE EAT *cake eat*}
 - Similar findings from with PCS users. Input/output asymmetry? (*Smith, 1996; Smith & Grove, 1999*)
- **Utterances with meaning **distributed** between modalities**
 - 19 utterances by all 6 speaking children eg.
 - EAT WALK *walk* SIT *sit* GIVE boy

1995 Main findings: morphology

- Children did produce modifications to signs that corresponded to changes in meaning and **increased effectiveness** of communication
 - 24 produced by 7 children; 18/24 contrastive
- These meanings were often interpreted by teachers even if they did not consciously register what the children were doing eg. *you saw the lights flashing; no hitting on the cheek, no;*
- *Grove et. al, 1996; Grove & Dockrell, 2000; Grove, 2019*
- These modifications **can be taught**, leading to systemisation (*Rudd Grove & Pring, 2007*)

Discourse and Discussion

- Children's long holds and sign repetitions allowed them to maintain their speaker turns
- Sophisticated use of deictic pointing as reference
- Use of deictics to include and exclude participants in discourse
- Use of sign and gesture to signify attitude "MAYBE..."
- *Grove, 2019; Parkhouse & Smith, 2019*

Where now?

■ Multimodality

- Sign and gesture are not **alternatives** to aided forms; abandon the attempt to match child to “system”

■ Co-production

- Children with developmental disabilities are creative innovators with language; our task is to explore their potential in each form, and respect and value their choices. Learn from them!

■ Intervention is a cultural initiative

- The introduction of new communication forms is a cultural innovation, not a toolkit for modifying behaviour. New forms are used when they are valued, promoted and modelled

■ Focus on use and development over time

- We know how to address all of these problems

The good news

- We've known the answers for over 30 years and they still aren't working!

The bad news

Translanguaging is a theory of language that refers to the ways in which multilingual individuals access and use their full linguistic repertoire when communicating. Translanguaging centers the languaging experiences and practices of multimodal language users as multilingual language users as it recognizes that “all translanguaging is multimodal” (García & Wei, 2014, p. 40). The theory suggests that instead of having two (or more) distinct language systems, multilinguals have one system that houses all of their meaning making tools.

In AAC: Saechao,
Privette & Kim (2025).

- 
- students should be supported to develop their communicative skills in different contexts through various means of communication, such as speech, body language, manual signs and other communicative tools (Skolverket, 2023).
 - Staff valued multimodality of Norrie 2021

Rensfeld et al 2024

- The SLPs seemed to experience that they had to interpret and define AAC's conceptual boundaries for themselves. When asked about whether it was clear which interventions with children/ youth with S/PIMD were to be classified as AAC, the answer was unanimously “no” and the participants imagined that perceptions of conceptual boundaries of AAC probably differed between SLPs. Several mentioned that the concept seemed to have been gradually broadened in recent years to include strategies for supporting interaction or cognition. The more complex the disabilities, the more unclear it seemed whether certain interventions were in fact AAC. “unanimously “no” and the participants imagined that perceptions of conceptual boundaries of AAC probably differed between SLPs. Several mentioned that the concept seemed to have been gradually broadened in recent years to include strategies for supporting interaction or cognition. 969-970

We are all languagers who use semiotic resources at our disposal in strategic ways to communicate and act in the world” (including those of us who do not use AAC as a primary communication form)

AAC users are in a constant state of language contact between spoken languages, written languages, and symbolated languages. Researchers and speech therapists alike struggle to define and assess the language skills and abilities of AAC users.

descriptions of language use by AAC users should focus on communication functions (e.g.,greeting, commenting, requesting, describing, gossiping,sharing a story), use of aided and unaided forms and systems

to communicate with others, and literacy. In the firstauthor's experience from a decade of clinical practice,AAC communicative success happens when students areunderstood sufficiently to get their wants, needs, and

desires met and have their ideas conveyed, with minimal communication breakdowns between them and their communication

	Communication observations		
	Functions	With whom	Context
Modalities			

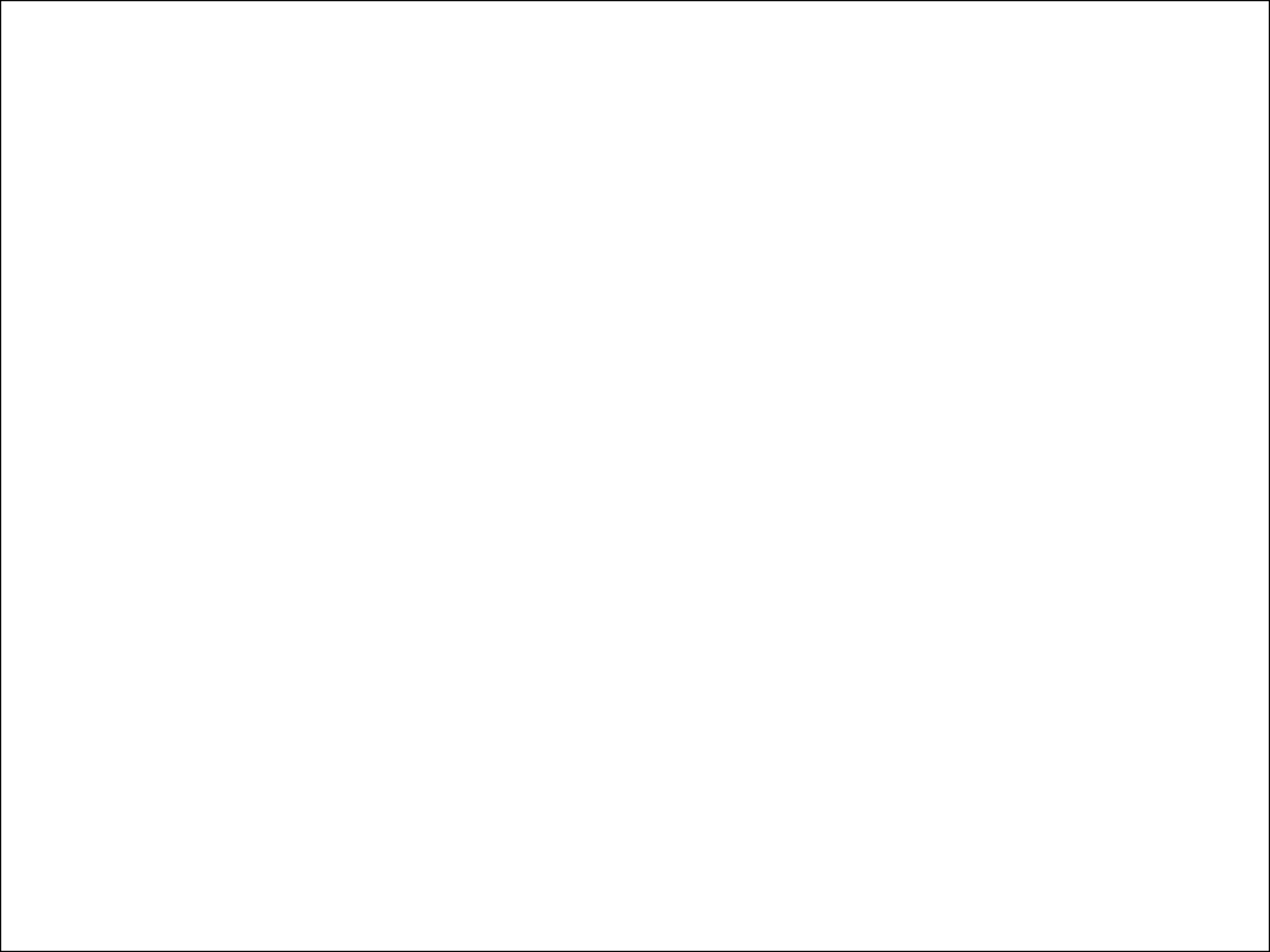

Semiotic
repertoires

Frames as the
focus of analysis

When thinking about semiotic assemblages, Canagarajah (this issue) proposes the unit of analysis could be 'activities' and 'frames'. A focus on activities (the approach taken by Canagarajah, Stone & Koehring, Goico, Tagg & Lyons and Boldt & Valente) means we ask the question: 'How do meanings emerge in the activity that semiotic repertoires are part of?' (Canagarajah, this issue)

In interactional analysis, therefore, researchers should be sensitive to how the repertoires of a community, participants, and those embedded in that setting work together in shaping communication for varying meanings and outcomes.

AAC COMMUNICATION MODEL

- Modalities code spoken language - signs translate words
- AAC system is activated at the point of transmission
- Structure of message derives from speech
- **Augmentative** and **Alternative** are equivalents

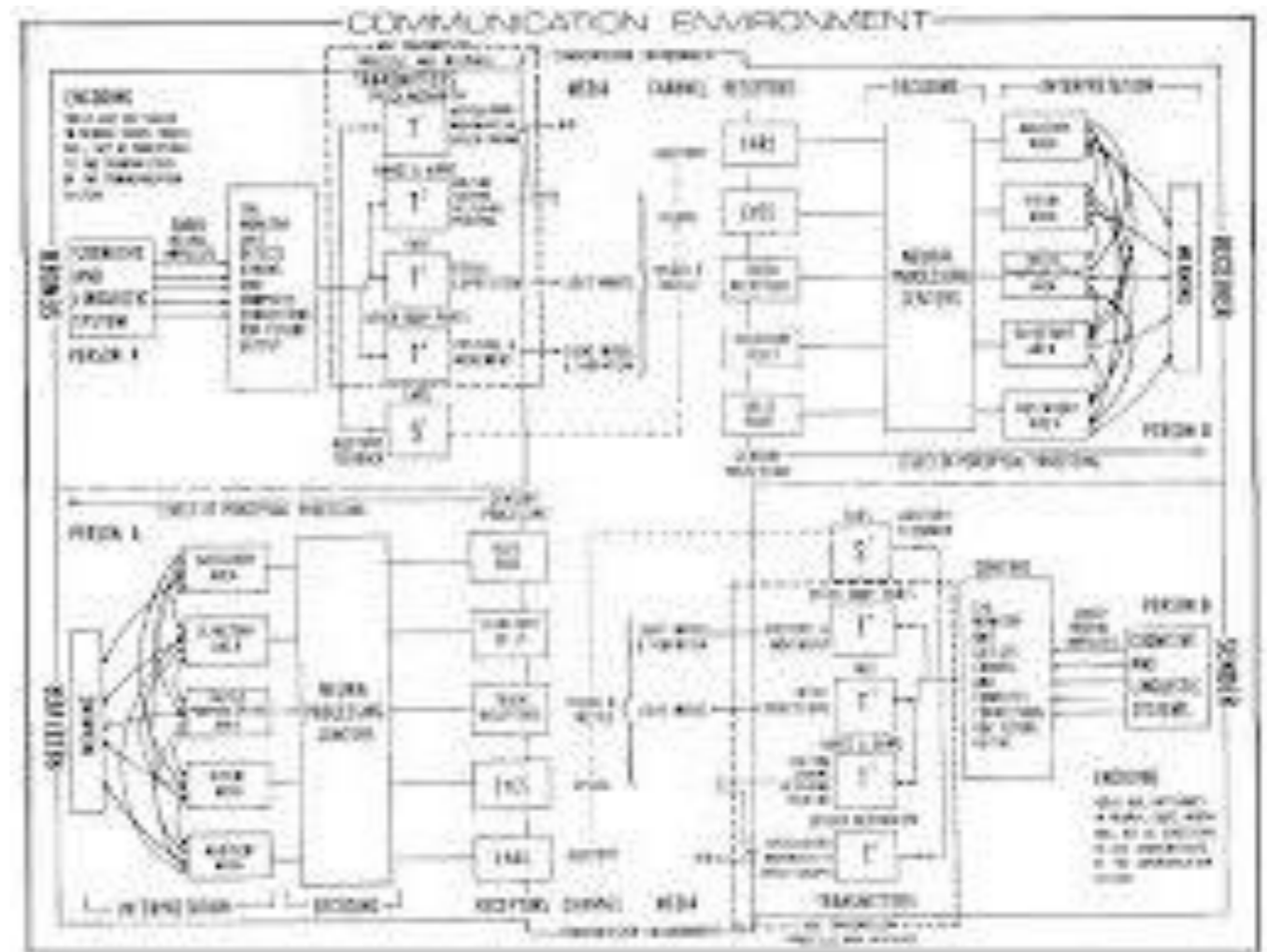

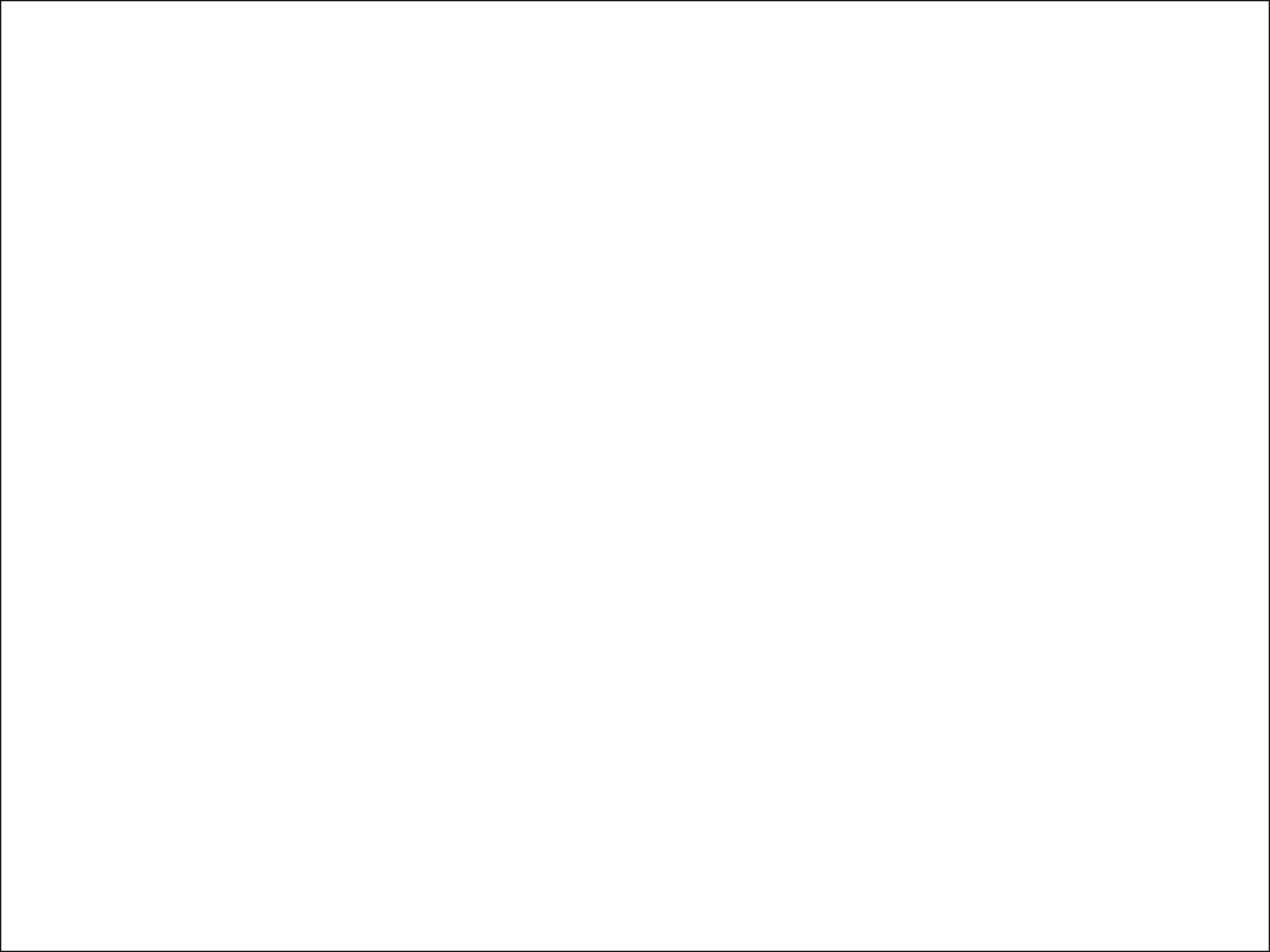

SIGN VARIATION

- Natural languages acquired through use
 - Home sign
 - Village sign languages (Martha's Vineyard)
 - Contact sign languages (pidgins, creoles)
 - International sign
 - Manual codes - compensatory strategies, taught
 - Signed English, MCE
 - PGSS
 - Cued Speech
 - KWS systems eg. Makaton, Signalong

AUGMENTATIVE & ALTERNATIVE COMMUNICATION

- Research and practice in late 1970s led to establishment of a distinct field of practice 1981 (ASHA)
- ISAAC founded 1983
- First International Conference Cardiff 1986 - followed by biennial conferences and research symposia
- Arlene Kraat's State of the Art research 1987
- Taxonomy & model developed and published 1990
 - *Aided communication*
 - *Unaided communication*

SIGN LANGUAGE: ATTITUDES TO KWS

- Need to emphasise linguistic status of sign as separate from spoken language
- Manually coded approaches seen as derogatory, oppressive, ineffectual and harmful in education
- Hierarchy of disability - distancing from historic equivalence of “deaf and dumb”
- Intellectual disability & Deafness seen as distinct categories: those with IDs are marginalised

SIGN INTERVENTIONS

- Main paradigm remains **behaviourist**
- Child as blank slate, learning through highly structured methods: imitation, prompt, reinforcement
 - Focus on 2 early functions: *mands* and *tacts*
 - Match system to child
- “..may have practical use, but do not explain how and why language develops” *Von Tetzchner, 2003, 10-11*

- “We don’t want to be known as a signing school” *New York special school for children with ASD*
- “Signing makes them look funny, so we don’t encourage it” *Overheard at ISAAC conference*

ATTITUDINAL BARRIERS

CHANGING SITUATION

- Continuing evidence that some children (including ASD) may show distinct preferences for sign
- Need to adopt a holistic, developmentally focused approach
- Increasing evidence of clinical population of deaf signing children with additional disabilities: ASD, Developmental Language Disorder in sign (SLI), children with CP needing aided systems
- Deaf signing parents may have children with intellectual disabilities who sign

RESEARCH STUDY
1986-1988
*Grove &
McDougall, 1991*

- Communication skills of children in London special schools using Key Word Signing (Makaton)
- 49 children CA 4;5-13;0 with severe intellectual disabilities
- Receptive language 13-52 months; Expressive language 14-41 months.
- Estimated expressive vocabularies 4-183 $X=72$ $SD = 43$
- 12 schools; 25 classrooms
- Observed in Teacher Directed Activity and Free Play with peers
 - Time sampling 20-30 minutes

MAIN FINDINGS

- Wide range of modality dependence (intelligible signs: intelligible words)
 - 16 “signers”; 11 “speakers”; 19 “in between”
- Limited range of pragmatic functions
- More signs directed to adults than peers in both settings
- Majority were single word/sign users
- † Positive association between signing by teachers, classroom sign environments and signing by children

An **AAC system** is an integrated group of components used to enhance communication. These components include forms of AAC (aided or **unaided**), symbols, selection techniques, and strategies..ASHA

AAC is a set of tools and strategies that an individual uses to solve everyday communicative challenges. Communication can take many forms such as: speech, **a shared glance**, text, **gestures, facial expressions, touch, sign language**, symbols, pictures, speech-generating devices....ISAAC

AAC Communication Model

- Modalities code spoken language - signs translate words
- AAC system is activated at the point of transmission
- Structure of message derives from speech
- Based on 1950s model of information processing: mind as computer

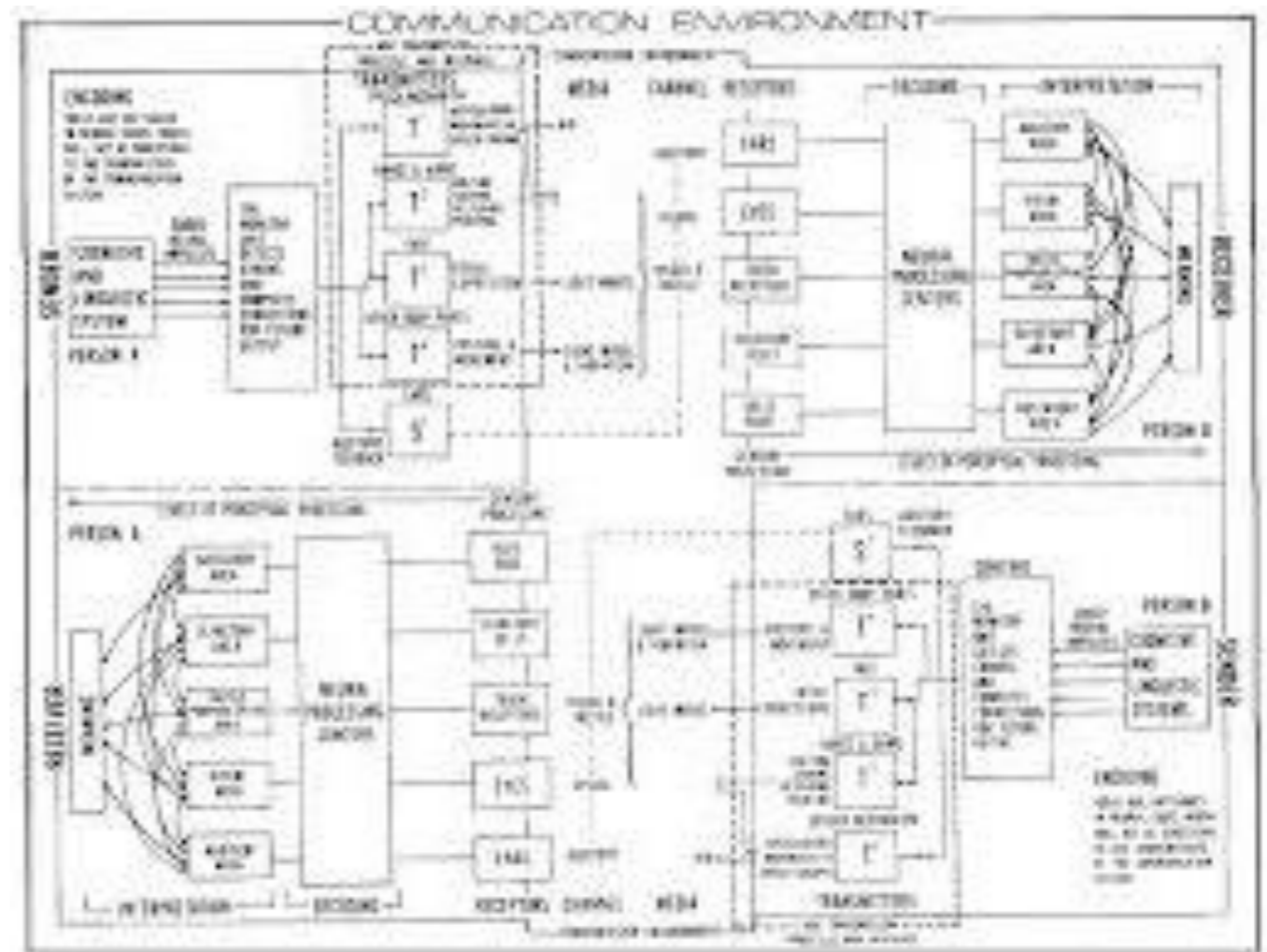

Lloyd, Quist & Windsor, 1990

SIGN ENVIRONMEN TS Classroom

- **HIGH SIGNING ENVIRONMENTS (n=18)**
- 4 Signs used by staff at all times, to all children as a class and in informal conversations (n=3)
- 3 Signs used consistently in routines, direct teaching and conversationally
- **LOW SIGNING ENVIRONMENTS (n = 7)**
- 2 Signs used consistently but only in specific routine situations
- 1 Signs used infrequently by staff, only in teacher-directed activities
- 0 No use of signing observed

- Children who spontaneously changed the form of their signs to communicate particular meanings
- Children who failed to reproduce the word order of the spoken input in their signed output

OBSERVATIONS

SIGN MODIFICATIONS

- Home signing deaf children change the citation form of signs to indicate changes in meaning
- They introduce systematic patterns of semantic relations in multi-sign/gesture utterances
- *Goldin Meadow, Singleton, McNeill*

RESEARCH STUDY
1990- 1994
*Grove &
Dockrell, 2000*

- Survey of multi-signing children in special schools in SE England (sign + point, sign + sign)
 - 61 children in 44 schools
- Observation and assessment of
 - 10 hearing multi signers in day special school
 - 4 non-speakers
 - 6 speech and sign
 - MLU (Sign) 1.31- 3.25 (Stage I=6; Stage II=4)

QUESTIONS

- What was the evidence of linguistic structure in the expressive communication of multi-signing children ?
- Syntactic
 - patterns of word order (sign should code ambient speech)
- Morphological
 - modifications to citation form of signs
 - as found in home signers
 - were these contrastive, consistent, generalised?

ASSESSMENT

- Picture test - *tell me which picture to point to*
- Big house /Small house; Boy wash car/wash dog; Ball inside cupboard/ next to cupboard
- Film story recall - *Spider Sandwich*
 - silent 3 minute film designed to elicit contrastive use of Handshape, Movement, Location & Orientation
- Conversation with teacher about a recent event

MAIN FINDINGS Syntax

- Word order did not always match that of the input
 - Agents preceded Actions; Patients preceded or followed Actions
 - Same patterns observed in speech and in sign - deviation from the input model {CAKE EAT *cake eat*} **and** {EAT CAKE *eat cake*}
 - Similar findings from Smith (1996) with PCS users
- Utterances with meaning **distributed** between modalities
 - 19 utterances by all 6 speaking children eg. {EAT WALK walk SIT sit GIVE} boy

MAIN FINDINGS Morphology

- Children did produce modifications to signs that corresponded to changes in meaning
 - 24 produced by 7 children; 18/24 contrastive
- These meanings were often interpreted by teachers even if they did not consciously register what the children were doing eg. *you saw the lights flashing; no hitting on the cheek, no*

CONCLUSIONS

- Multi-signers are operating at a pre-syntactic level - WHY?
- Code model inadequate to explain what children actually communicate
 - Input/output asymmetry proposed as a possible source of the problem (Smith & Grove 1999)
- Constructivism offers better explanations than behaviourism: Children are creative innovators and capable of exploring the potential of a visuo-spatial modality
- Value of incorporating perspectives from sign linguistics with a clinical population regarded as the domain of AAC

RESEARCH STUDY
2005-2006
*Rudd, Grove &
Pring, 2007*

- Exploration of **productive** use of sign modifications
- 8 multi-signing children with IDD's aged 6;1-10;11 (MA on BPVS 3;0-5;10)
- Productivity
 - *Contrastive* (citation form vs. modified form)
 - *Consistent* (in obligatory contexts eg. FLY-up WALK-up)
 - *Generalised* (use across pictures and objects)
- Matrix training procedure

Matrix Training

Romski & Ruder, 1984

Verbs

WALK FLY JUMP CRAWL

Modifiers

up

X

X

down

X

X

fast

X

X

slow

X

X represents trained items:
generalisation tested with untrained items

RESULTS

- On pre-testing, children already showed evidence of contrastive, consistent and generalised use
- Post- intervention, 7/8 children showed productive use of modifications
- Productive use of all sign modifications improved significantly: taught signs > untaught signs

RESEARCH STUDY

Woll & Grove, 1996

- Hearing twins with Down Syndrome born to profoundly deaf native signing parents
- British Sign Language their first language
- Used speech and sign
- Assessment revealed they had problems with the syntax and morphology of BSL, both expressively and receptively
- Conclusion: the language difficulties associated with DS apply cross-modally and are not solely due to issues of auditory-vocal processing

Sign Language offers AAC....

- Broader context of language acquisition
- Insights into interactions between modalities
- Gesture/Language dynamic relationship
- Understanding of factors impacting on development and use eg. handshape acquisition
- Use of technology by deaf populations - eg impact on eye contact
- Understanding of sign and gesture in discourse

AAC offers Sign Language

- Understanding of communication technology
- Analysis of the impact of aided systems in discourse
- Empowerment - role models of ambassadors with severe communication disabilities

TOMORROW....

- Status and respect for signers who have intellectual and developmental disabilities
- Raise expectations
- Focus on **use** and **development** over time
- Informed application of sign research findings in AAC intervention practice
- Recognition of intersectionality: shared agendas

ACKNOWLEDGEMENTS

- Funders: Leverhulme Foundation, Economic and Social Research Council
- Mentors and colleagues: John Bonvillian, Filip Loncke, Bencie Woll, Julie Dockrell, Stephen von Tetzchner, Martine Smith, Kaisa Launonen
- All of you - for staying the course! (if you did)

The overriding goals of an AAC system should be to provide a means for the individual to say what she wants to say and how she wants to say it, when she wants, and to whom she wants. Autonomy of an individual's communication should be central.

The design of an AAC system incorporates each individual's strengths and needs. It incorporates the individual's full communication abilities and may include existing speech, vocalizations, **gestures**, languages spoken, and/or some form of external system

ISAAC & ASHA websites

Ricky 2019

- Ricky is a 4 year old with delayed speech and language due to a rare genetic condition
- On observation he was only partially intelligible, but was using gesture effectively to get his messages across
- His family say gesture is a strength
- The reports make no mention of his gestures; the SLP intervention is to use PCS prompts to develop SVO structures to describe black and white line drawings. Ricky and his parents find this discouraging because it highlights his difficulties
- After a month of the family reinforcing and modelling gesture with him, his speech is improving as is his confidence

Children needing alternatives to speech

- 7% of children in USA have a developmental disability ASHA 2015
- c. 12% of preschoolers enrolled in special education services in Pennsylvania required AAC (Binger & Light, 2006)
- They used a variety of strategies:
 - gestures 62% sign language 35%
 - pictures 63% objects 31% SGD 15%

How have we
got here? Sign
languages and
AAC:

SIGN LANGUAGES

Difference, not
disability

AAC users severe expressive
communication disorders: deficit model

The digital age:
universal access to communication technology

Sign systems paired with speech fail Deaf
children and are seen as oppressive
imposition by dominant culture

1990 Taxonomy: Aided/Unaided
Signs are "unaided AAC forms"
Input always paired with speech

Sign is a natural primary language, rule governed
Central to the identity of Deaf people

1984, 1986 ISAAC conferences
981 ASHA 1983 ISAAC

1979 Sign Language
International conference
1972 Sign Language Studies
1960s first SL teaching at
Gallaudet

1970s Manual sign use with adults & children with IDD
Consultations with experts in SL
Exchange of knowledge in research papers and in
practice
Liz Levitt, Margaret Walker, John Bonvillian, Madge Skelly

INTERSECTIONALITY

Contact languages
Bimodal forms of communication
between users of different languages
with different levels of ability:
sign + speech variants

Increasing recognition of
language delay and disorders
amongst Deaf signing children

Individuals who are both D/deaf
& intellectually disabled
Where do they belong?

Children who don't profit from CI;
often with additional SENDs

HCDP with sign as FL
who have developmental disabilities

Alternatives to Speech: AAC interventions

- Arose from recognition that speech training does not work for all
- Speech viewed as primary, default modality to which we should aspire: most users operating within the “hearing world”
- Drive from manufacturers and innovators: “AAC consumers”; digital advances
- High status in AAC historically associated with CP and intact cognition

Features and access strategies must be carefully matched to the individual's requirements. Systems require training for the user, and often for communication partners who will be interacting with and supporting the user. Backup systems and **creating an aided language learning environment** for the user may also be critical. Repair and ongoing tech support for high tech devices will also be needed. Selecting a **pre-designed, carefully thought out language system**, and then customizing vocabulary and messages, is an on-going process that should be periodically revisited as an individual's needs or situation changes. **This process is updated as new technologies are invented**, and/or a person's needs or environment changes. For many individuals, this will continue to be important throughout their lifetime.

A Comprehensive Assessment for AAC

- Current communication skills
- Speech sounds, spoken language, written language
- Symbols
- Feature matching for appropriate AAC system
 - Device type, display, selection method, positioning

Attitudinal Barriers

- “We don’t want to be known as a signing school” *New York special school for children with ASD (Von Tetchner, 2019)*
- “Signing makes them look funny, so we don’t encourage it”
Overheard at ISAAC conference
- “It might stop her speaking...”
“social worker to mother of DS child, 2019
- Ipad with speech rated as more acceptable than sign *Schäfer et al, 2016*

Sign
Languages,
Gestures &
Key Word
Signs

Sign Languages

- Natural languages of deaf people
- Central to Deaf cultural identity
- c. 170 languages worldwide, used by millions
- Lexicons differ (c. 30% iconic signs shared between any 2 sign languages);
- Grammatical structures similar - topic-comment structure; spatial grammar; classifier incorporation; simultaneity
- Separate from speech

- Linguists see gesture as vocal as well as manual
- Dynamic , fluid relationship *Goldin Meadow & Brentari, 2015*
- Deictic - pointing out.....
 - Take on pronominal/referential role in SL
- Representational - iconic form/meaning correspondence
 - Basis for generation of signs, new sign forms
- Conventional - culturally agreed forms
 - About 30% of signs are effectively symbolic; non transparent or translucent
 - Meanings are conventionally motivated and agreed

Sparaci et. al., 2019

Gesture Development

- Emerge preverbally, becoming formalised eg. clapping, “give me” “I don’t want it”
- Gesture use correlated with later language development
- 18-24 m. Manual gesture use is high, co-existing with speech, bimodal production common where one component is spoken and another gestured eg. “pretty BUTTERFLY”. Predicts onset of 2 word combinations
- Gesture continues throughout childhood and adulthood allowing us to explain, formulate ideas.
Sparaci et al. 2019; Meier, 2019

From Gesture to Language

- “Home signing” deaf children -oral input, autonomous discovery of sign -
- change citation form of sign/gesture to indicate changes in meaning
- They introduce systematic patterns of semantic relations in multi-sign/gesture utterances
- *Goldin Meadow, Singleton, McNeill*

Manual modality...impact on speech

- Natural co-existence; neural links
- Facilitates expression of ideas (*McNeill, Kendon, Goldin Meadow*)
- Improves intelligibility of spoken words (*Powell & Clibbens, 1994*)
- Early introduction of sign promotes spoken language in children with DDs (*Launonen, 1996; 2003; 2019*)

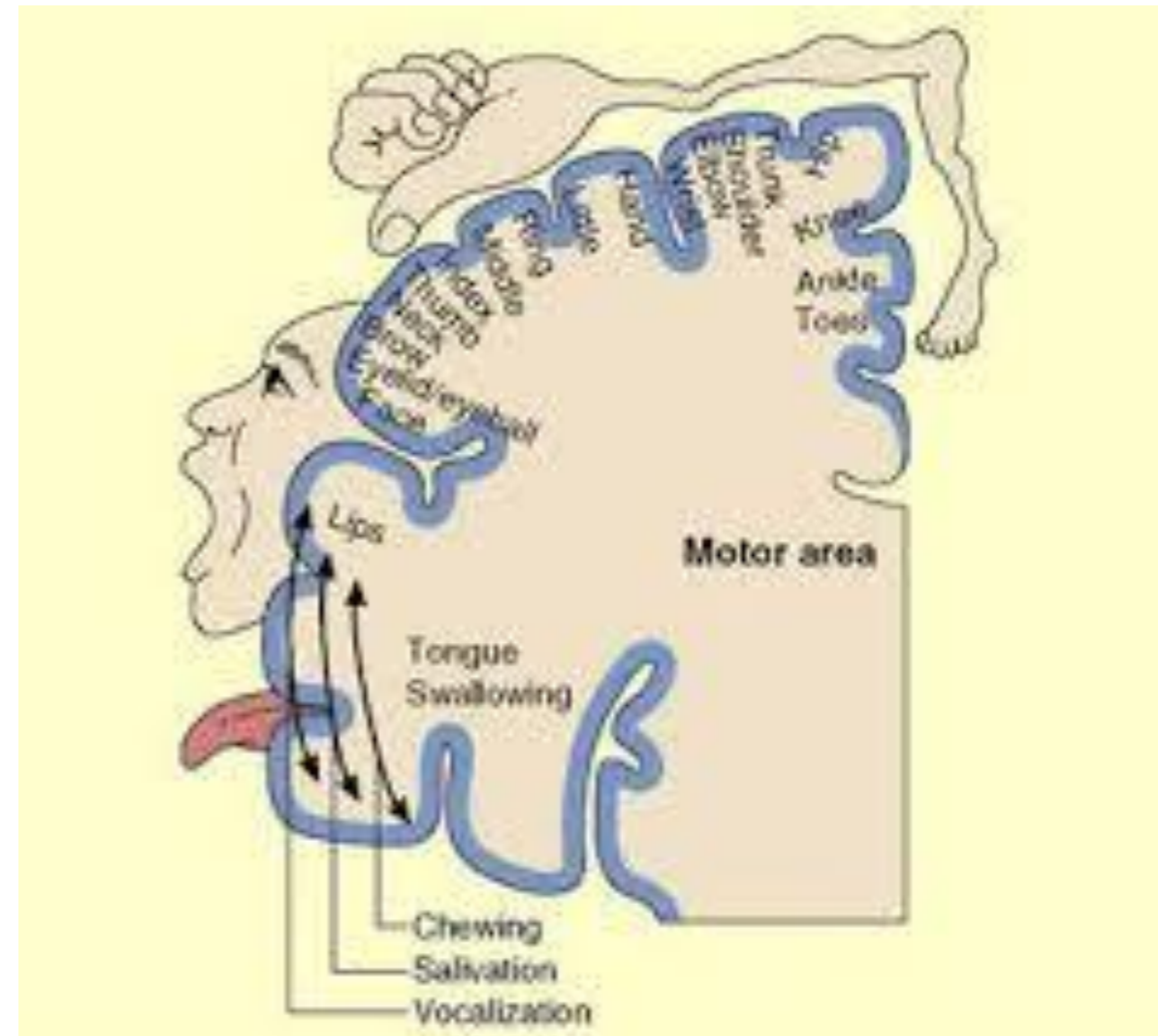

Key Word Signing (KWS)

- Describes input TO the child
- Natural spoken language is used
- “Key words” are signed: usually 1 or 2 per clause
 - Put the book/BOOK on the table
 - Put the book/BOOK on the table/TABLE
 - Put the book/BOOK on/ON the table/TABLE
- Most commonly used approach with children and adults with IDs
- Similar strategies found in interactions between hearing and Deaf people (hearing people with very little sign knowledge)

Sign Interventions in AAC

- Main paradigm remains **behaviourist**
- Child as blank slate, learning through highly structured **training**: imitation, prompt, reinforcement, generalisation
 - Focus on 2 early functions: *mands* and *tacts*
 - Match system to child
- “..may have practical use, but (does) not explain how and why language develops” *Von Tetzchner, 2003, 10-11*

- Eight year follow up of children with DS.
(*Launonen, 2003; 2019*)

How do Key
Word Signers
develop over
time?

Eric: 0:10 - 17:4

- DS. Severe apraxia of speech , no vocalisation
- No spoken words at 3;8, signs introduced
- Quickly learned to sign, dominant language form till 15;0. Many sign modifications
- At puberty, developed deep voice, started to use more spoken words
- At 17;4 relied on speech augmented by sign/gesture
- (*Launonen & Grove, 2003; Launonen, 2019*)

Geoff: at 6 and at
46

- Autistic
- taught several signs at 6 years of age
- 40 years later, he is still signing, developing new concepts, communicating with staff who are fluent signers and using signs such as BEAUTIFUL, YOU'RE WELCOME; BE PATIENT
- *Webster et. al., 2016*

DAVID: at 4 and at
37

- Severely apraxic, moderate ID
- Plenty of unintelligible vocalisations. Learned signs from 4;0 onwards; SGDs introduced early
- At 37 uses consistent CV spoken words; signing more enthusiastically now he is part of a community of signers.
- Left his very expensive new SGD on a train. He just doesn't like it. Does use iPad with symbols and photos

Katie over 15 years

- CP, brought up in care “severely disabled” “all arms and legs” “nonverbal” “relies on body language”. Went into adult foster care at 15; carer was classroom assistant
- Grandson aged 4 described how she “talks to me”
- Sophisticated set of gestures based on physical characteristics to refer to people she knew
- “I’ve never seen that at school!” “She only talks to children!”
- Subsequently observed signing at club with child with DS. Stopped when adults came along
- SLP “So we missed out on all that potential. We gave up on Makaton. We thought she was too disabled - physically and mentally. I bet she learned it from the other children. Perhaps when we gave up on her, she gave up on us”.
- *(Personal communication, Gill Levy RNIB)*

Assessment and Intervention

Assessment

- Familiarise yourself with sign language and gesture development (*Meier, 2019; Sparaci et. al, 2019*);
- Understand sign phonology (*Grove et. al., 2019; Grove, 1990*)
- Observe what resources children are **already** deploying (*Rudd, Grove & Pring, 2006*)
- Adopt a multimodal, co-operative perspective
 - “co-operative transformation zones where the individual decomposes and reuses current resources to create something else” *Goodwin, 2013*

Pragmatic
Perspective:
function x
modality x
context

- Functions (*Halliday, 1976*)
 - *request, tell, express feelings, negate, social, play and joke, conversational, narrate, imagine, problem solve, explain....*
- Modalities
 - *Vocal,/verbal manual/sign, body, face, eye gaze, object use, graphic*
- Context
 - *Who, when, where etc*
- Available at drnicolagrove.com. Cf *Marilyn Buzolich Communication Sampling*

Intervention: Maximise creativity

- Adopt co-production: working with the child
- Principle of Relevance (*Sperber & Wilson, 1986*)
- Model- children do better if they see signing in action
- Provide communication challenges
 - Naive listener: narrative; barrier communication games
 - Use film NOT static pictures
- Involve them in debates about issues that matter to them
- Bring in expert signers: drama, dance, poetry

We argue that in order to meet deaf children's specific biological and linguistic needs, these children's right to sign language also needs to be recognized as an analogous ground for protection from discrimination. Sign language rights are framed in terms of an immutable characteristic of all children, namely the *biolinguual process* for language acquisition. The *biolinguual process* is the experiential and innate ability to acquire language.

J. Paul, 2017

Thank you to....

- Funders: Leverhulme Foundation,
Economic and Social Research Council
- Mentors and colleagues: John Bonvillian,
Filip Loncke, Bencie Woll, Julie Dockrell,
Stephen von Tetzchner, Martine Smith,
Kaisa Launonen
- Kathy Howery and the team
- All of you - for staying the course! (if you
did)